

# Technical University of Madrid Online Master's Degree

Numerical Simulation in Engineering



**Ansys**

## Numerical Simulation in Engineering with Ansys

The Technical University of Madrid (UPM) offers an online master's degree with the goal of training experts in the computational simulation of fluid mechanics, solid mechanics and electronics using Ansys engineering simulation software.

The curriculum is oriented toward practical applications, relevant for a range of industries (energy, automotive, aeronautics, construction, civil engineering, naval, railway, industrial equipment, etc.).



+

**Ansys**

# Included Content

1

Program Structure and Degrees

2

Course Portfolio

3

Learning Method

4

Degree Benefits

5

Teaching Staff

6

Calendar & Fees

# Program Structure & Degrees

Numerical Simulation in Engineering

**Ansys**

# Program Structure

Levels	Modules	Disciplines	ECTS Credits
<b>Basic</b>	Fundamentals and Application of Finite Element Method in Mechanical Analysis	Solid	20
	Fundamentals and Application of Computational Fluid Dynamics	Fluid	20
	Introduction to Electromagnetics: Theory and Simulation	Electromagnetics	20
<b>Advanced</b>	Dynamic Analysis	Solid	20
	Thermal Analysis	Solid	10
	Contact Non-Linearities	Solid	10
	Advanced Non-Linearities	Solid	10
	Fracture and Fatigue	Solid	10
	Solids Optimization	Solid	10
	Turbulence	Fluid	10
	Multiphase	Fluid	20
	Heat Transfer	Fluid	10
	Combustion and Reactions	Fluid	10
	Turbomachinery	Fluid	10
	Fluids Optimization	Fluid	10
	Fluid-Structure Interaction	Solid, Fluid	10
<b>Master's Thesis</b>		Solid, Fluid	20

# Three Levels of Professional Degrees

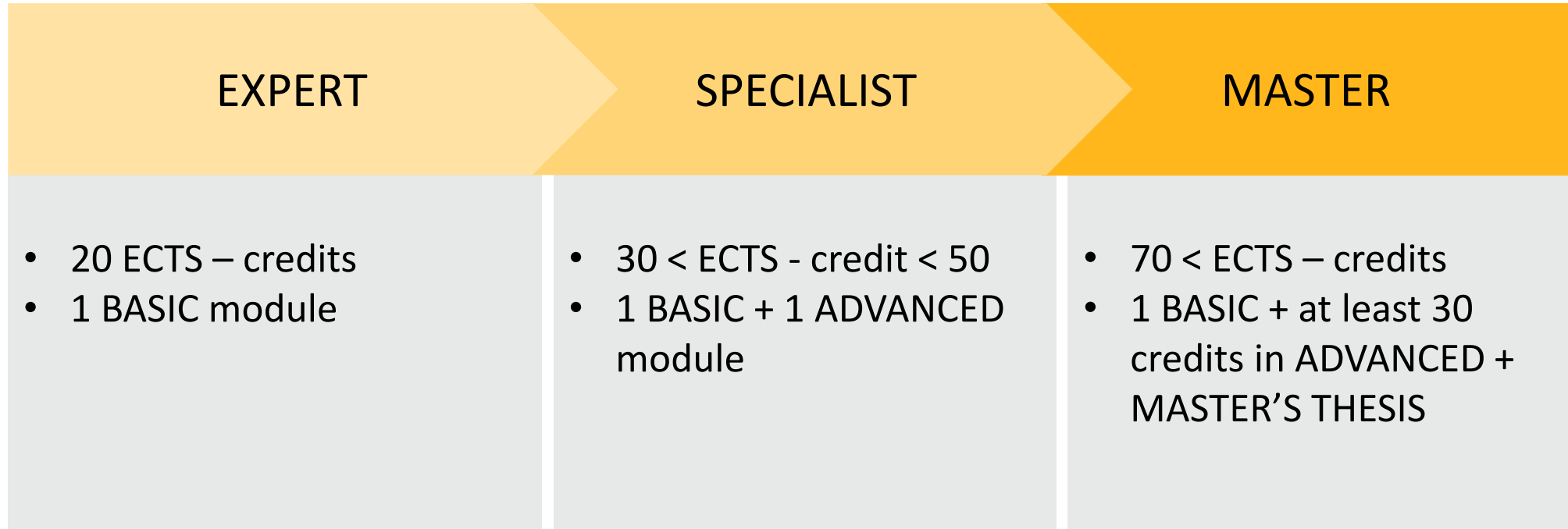

# Curriculum Areas of Focus

## Students interested in Solid Mechanics should take:



- Solid Basic Module: Fundamentals and Application of Finite Element Method in Mechanical Analysis
- One or several Solid Advanced Modules: Dynamic Analysis, Thermal Analysis, Contact Non-linearities, Advanced Non-linearities, Fracture and Fatigue, Optimization
- Master's Thesis

## Students interested in Fluid Mechanics should take:



- Fluid Basic Module: Fundamentals and Application of Finite Element Method in Mechanical Analysis
- One or several Fluid Advanced Modules: Turbulence, Multiphase, Heat Transfer, Combustion and Reactions, Turbomachinery, Optimization
- Master's Thesis

## Students interested in Fluid-Structure Interaction should take:



- Two Basic Modules: Fundamentals and Application of Finite Element Method in Mechanical Analysis and Fundamentals and Application of Computational Fluid Dynamics
- Advanced Module of Fluid-Structure Interaction
- Master's Thesis

## Students interested in Electronics should take:



- Basic Module: Introduction to Electromagnetics: Theory and Simulation

# Program Duration

The duration of each module is 1 semester on a four-month period, while the duration of the Master's Thesis is between 1-2 additional semesters.

Semester	Example 1	Example 2	Example 3	Example 4
1	Basic Module			Basic Module
2	AM 1   AM 2   AM 3	AM 1   AM 2   AM 3	Advanced Module 1	Advanced Module 1
3	Master's Thesis			AM 2   AM 3   Master's Thesis
4			Advanced Module 3	
5			Master's Thesis	
6				

AM = Advanced Module

In order to enroll an advanced module, the student will have to have passed the corresponding basic module(s).

In order to enroll in the Master's Thesis, the student will have to have passed, at least, 30 credits, and enrolled in 20 credits.



# Inclusions in a Module

## **Student has access to the following during the semester:**

- Moodle, the course virtual classroom
- Ansys software and License
- Evaluations

## **If the student fails a module:**

- If the student fails the course at the end of the semester, he/she will have the right to an extra exam session to be taken four months after the regular exam.
- To prepare for this extra exam, the student will have access to Moodle and to an Ansys license prior to the exam.
- If the student fails the extra exam, he/she would need to enroll in the module again as well as pay the fees corresponding to that module.

# Inclusions in the Master's Thesis

## The student has access during a minimum of 1 semester and a maximum of 2 semesters:

- Professor tutorship of the project
- Ansys software and License
- Evaluation of the master's thesis at the end of the first and/or second semester

## If the event a student fails the Master's Thesis:

- If the student failed or did not show up at the thesis in the second semester's evaluation, he/she would need to enroll in the master's thesis as well as pay again.

# Course Portfolio

Numerical Simulation in Engineering

**Ansys**



The objective is to provide the adequate theoretical and practical background to analyze fluid mechanics problems through numerical simulations.

## Basic Module

- Fundamentals and Application of Computational Fluid Dynamics

## Advanced Modules

- Turbulence
- Multiphase
- Heat Transfer
- Combustion and Reactions
- Turbomachinery
- Fluids Optimization



## MODULE OBJECTIVE

The objective of this module is to provide the adequate theoretical and practical background to analyze fluid mechanics problems through numerical simulations based on the finite volume method (FVM) with Ansys CFD.

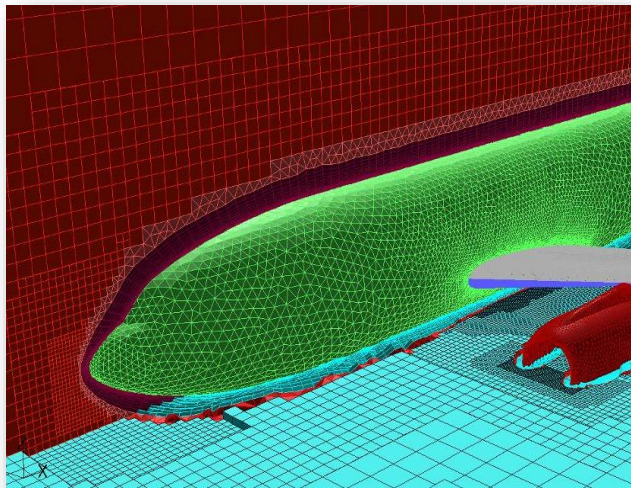
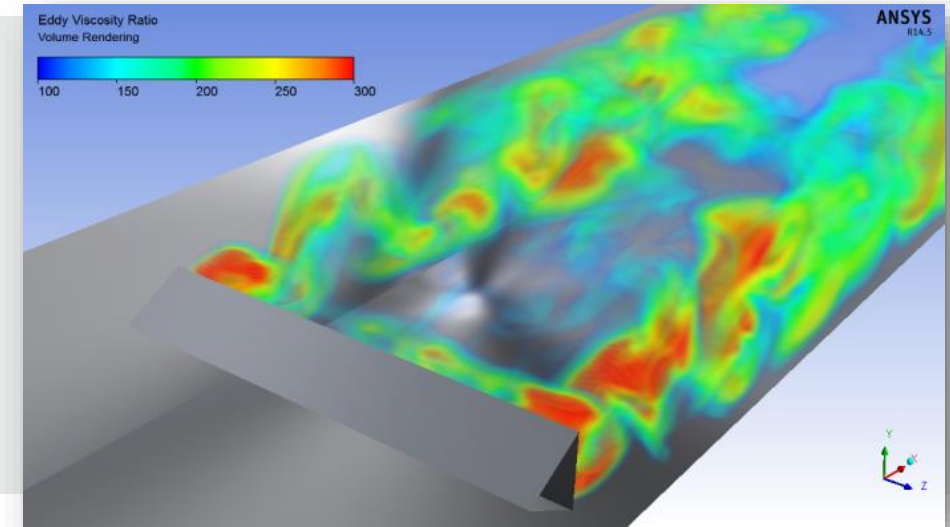

**CREDITS: 20**

**TOPICS:**

- Fundamentals of CFD
- CFD Pre-Processing : Geometry, Mesh
- Incompressible/Compressible Flows
- Introduction to Turbulence Modelling
- Numerical Performance Optimization
- Industrial Applications



## MODULE OBJECTIVE

The objective of this module is to detail advanced turbulence modelizations and allows the student to be able to accurately simulate all turbulent engineering flows with Ansys CFD.

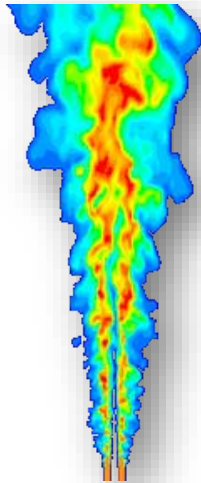
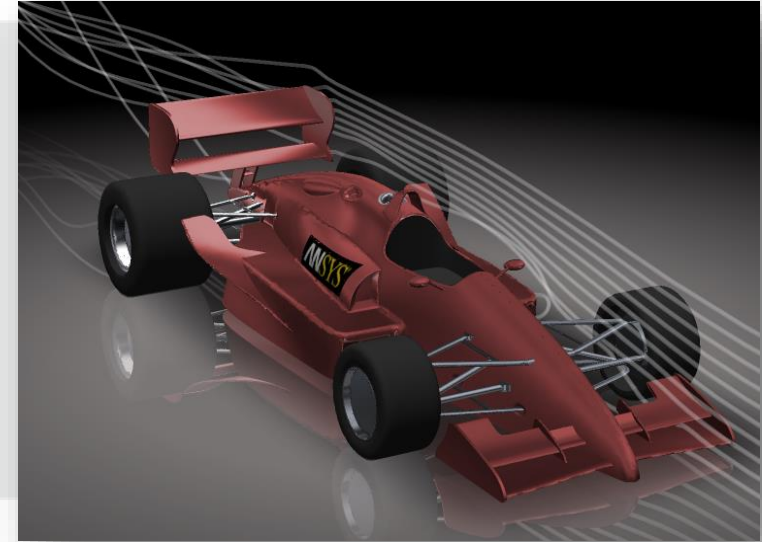

**CREDITS: 10**

**TOPICS:**

- Fundamentals of Turbulence
- Turbulent Eddies and Boundary Layers
- Advanced RANS Models (RSM, transition,...)
- Scale Resolving Models (LES, DES, SAS,...)
- Model Evaluation / Best Practices



## MODULE OBJECTIVE

The objective of this module is to present all models available in Ansys CFD focusing on capabilities and setup for Multiphase modeling.

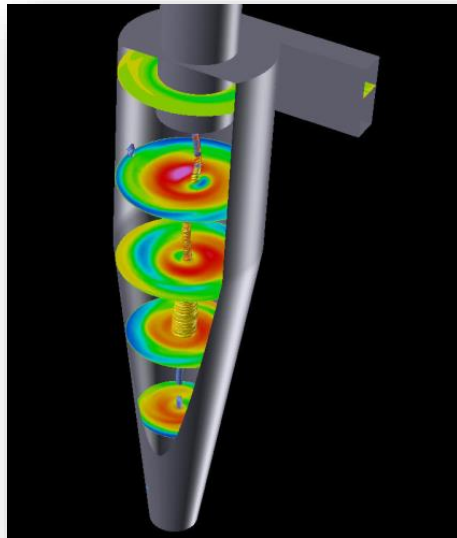
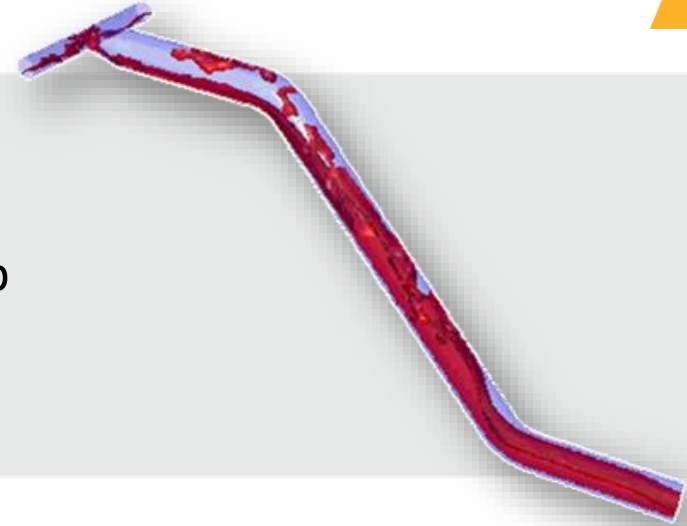

**CREDITS: 20**

### TOPICS:

- Particulate Flows
  - Sprays, Chemical Reactions, Particle Size Distribution,...
  - Eulerian Flows
    - All Flow Regimes
    - Gas/Liq, Gas/Solid, Liq/Gas and Liq/Solid
- Eulerian Wall Film
  - Free Surface Flows
  - Phase Interaction
    - Drag, Lift,...
    - Condensation, Evaporation, Boiling



## MODULE OBJECTIVE

The objective of this module is to present all modes of heat transfer and allows the attendee to be able to set up and solve them with Ansys CFD.

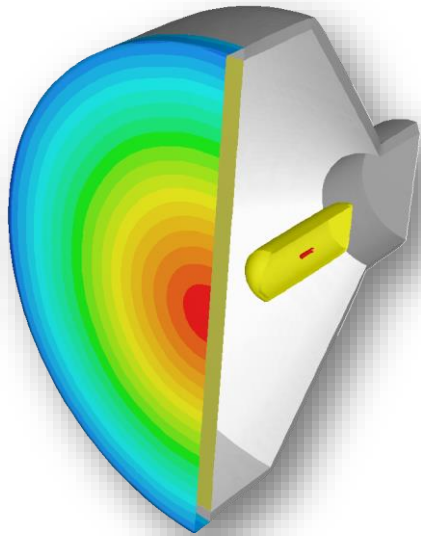
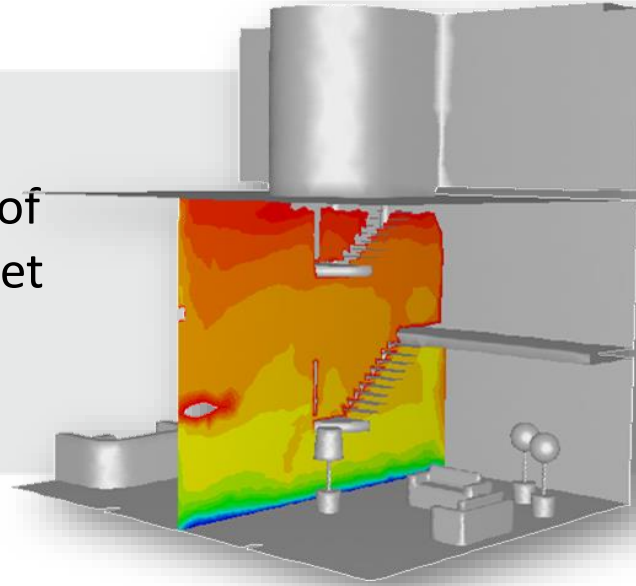

**CREDITS: 10**

### TOPICS:

- Conduction
- Convection (forced and natural)
- Fluid-Solid Conjugate Heat-Transfer
- Radiation
- Interphase Energy Source
- Heat Exchangers





## MODULE OBJECTIVE

This module will provide detailed background on reacting flow models allowing the attendee to be able to accurately simulate reacting flows in steady and unsteady analysis in Ansys CFD.

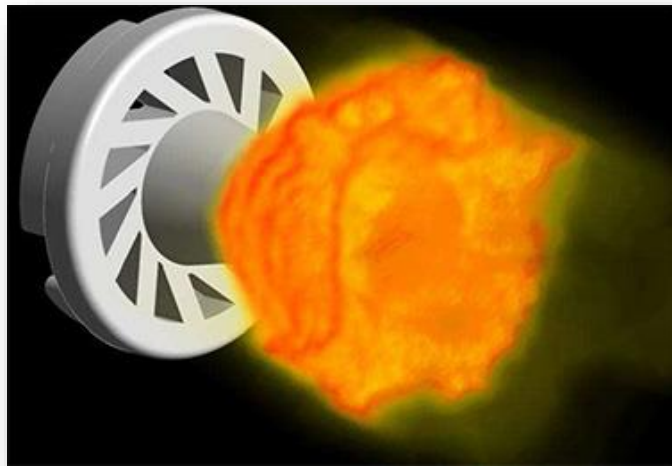
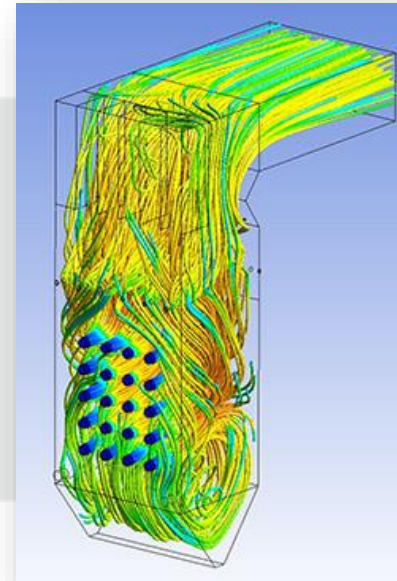

**CREDITS: 10**

**TOPICS:**

- Species Transport
- Non-Premixed, Premixed & Partially Premixed Flames
- Discrete Phase Reaction Modelling
- Detailed Chemistry & Chemistry Acceleration
- Surface Reactions



## MODULE OBJECTIVE

The objective of this module is to present various levels of modeling of turbomachinery from 2D blade models to full rotor unsteady simulations with Ansys CFD.

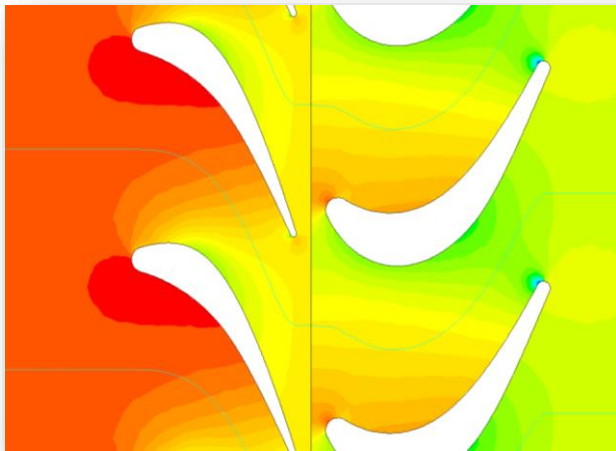
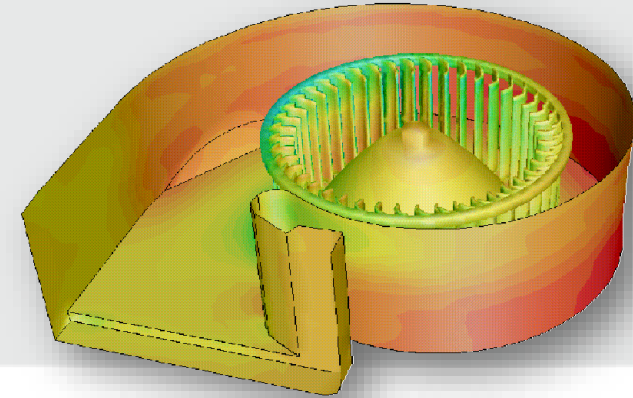

**CREDITS: 10**

**TOPICS:**

- Fundamentals of Rotating Machines
- Simplified Blade-to-Blade and Through Flow Models
- Modelizations of Turbines and Compressors
- Steady CFD Approach (MRF)
- Transient CFD Approach (Sliding Mesh)



## MODULE OBJECTIVE

The objective of this module is to obtain both the theoretical and practical knowledge related to optimization in Fluid Mechanics with Ansys.

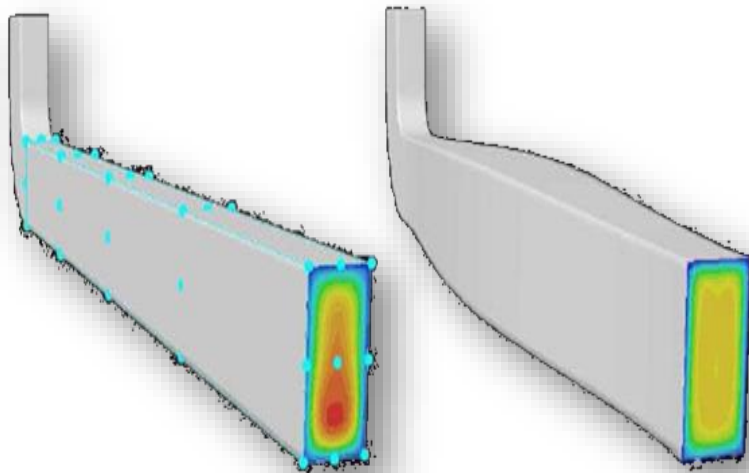
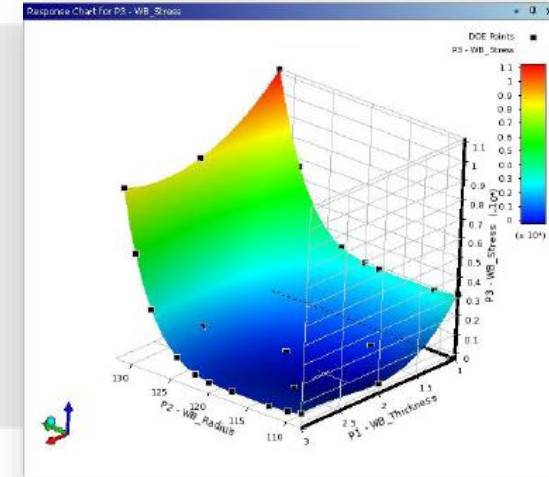

**CREDITS: 10**

### TOPICS:

- Parametric Optimization with DesignXplorer
  - Parameters Correlation
  - Design of Experiments
  - Response Surface
  - Goal Driven Optimization
  - Robust design and Six Sigma Analysis
- Fluids Topological and Shape Optimization
  - in Ansys FLUENT with Adjoint Solver and Mesh Morpher Optimizer



The objective is to provide the adequate theoretical and practical background to analyze mechanical problems through numerical simulations.

## **Basic Module**

- Fundamentals and Application of Finite Element Method in Mechanical Analysis

## **Advanced Modules**

- Contact Non-linearities
- Advanced Non-linearities
- Dynamic Analysis
- Thermal Analysis
- Fracture and Fatigue
- Solids Optimization



## MODULE OBJECTIVE

The objective of this module is to provide the adequate theoretical and practical background to analyze mechanical problems through numerical simulations based on the finite element method (FEM) with Ansys Mechanical.

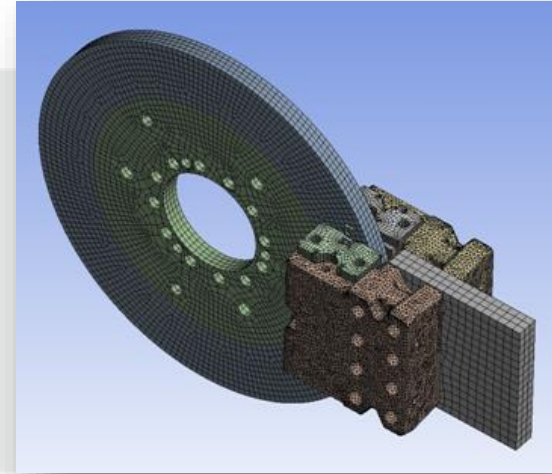

B: Static Structural  
Equivalent Stress  
Type: Equivalent (von-Mises) Stress  
Unit: MPa  
Time: 1

0.059411 Max  
0.051921  
0.045431  
0.038941  
0.032451  
0.025961  
0.019471  
0.012981  
0.006491  
1.011e-6 Min

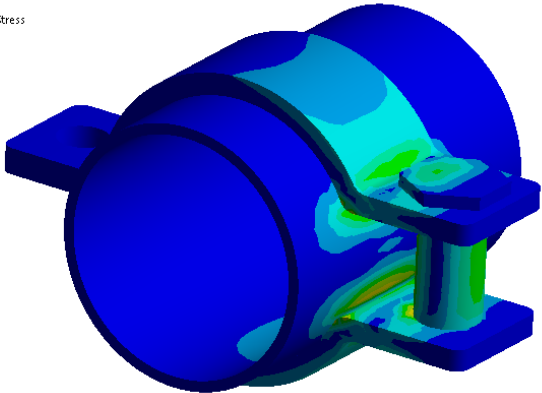

**CREDITS: 20**

**TOPICS:**

- Fundamental Concepts of FEM: 1D Problems
- 2D and 3D Elastostatics
- Isoparametric Elements
- Geometry Preparation and Meshing Techniques
- Definition of Boundary Conditions and Loads
- Plate and Beam Modelling
- Potential Problems
- Linear Buckling Analysis
- Introduction to Modal Analysis
- Nonlinear Analysis



## MODULE OBJECTIVE

This module is intended to provide a theoretical and practical background in Computational Contact Mechanics. Types of connections like gasket joints and prestressed bolts will be also addressed.

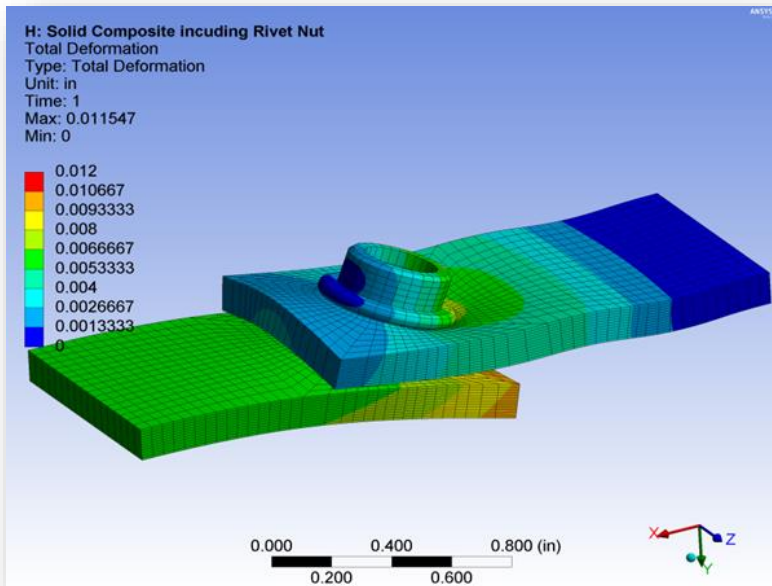
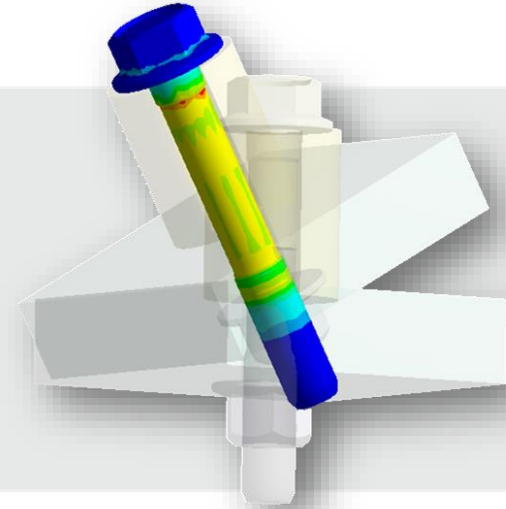

**CREDITS: 10**

**TOPICS:**

- Basic Concepts
- Types of Contact
- Normal and Tangential Contact Methodologies
- Contact Detection Methods
- Finite Element Implementation of Contacts
- Contact Post Processing
- General Joints
- Bolt Pretensions
- Gasket Joints



## MODULE OBJECTIVE

This module will provide the adequate theoretical and practical background to perform advance structural nonlinear analyses with Ansys Mechanical. Geometric and Material non-linearities will be covered.

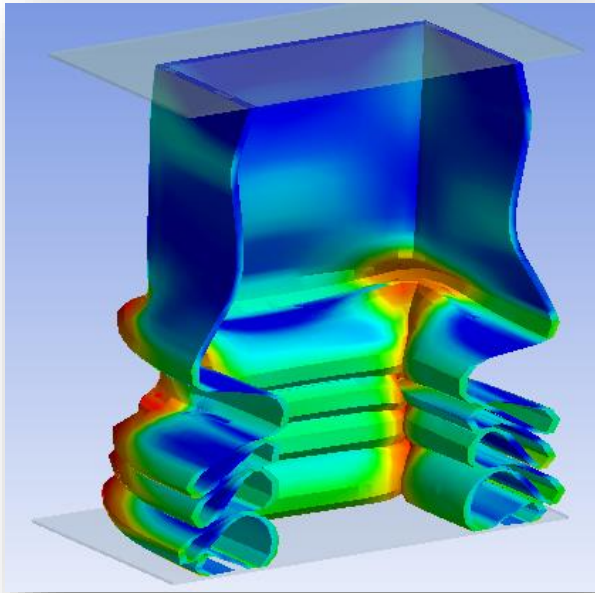
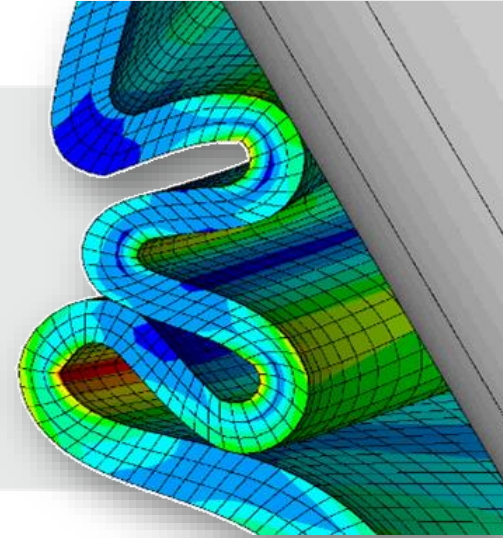

**CREDITS: 10**

**TOPICS:**

- Non-linear Solution Diagnostic
- Geometric Non-linearities: Structural Buckling
- Non-linear Material Models:
  - Plasticity
  - Viscoplasticity
  - Creep
  - Hiperelasticity
  - Viscoelasticity
  - Advanced Models



## MODULE OBJECTIVE

This module will provide the adequate theoretical and practical background to analyze dynamic problems through numerical simulations based on the finite element method (FEM) with Ansys Mechanical.

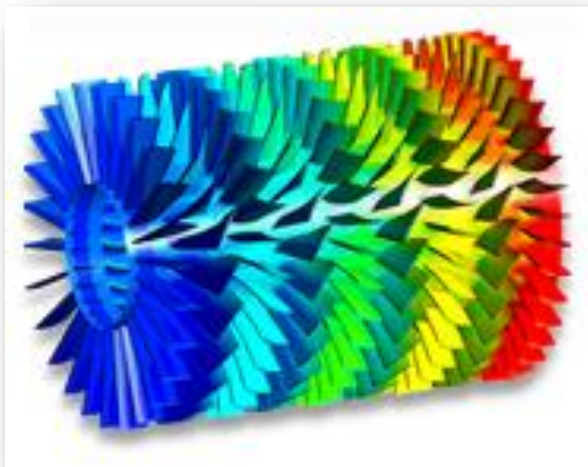
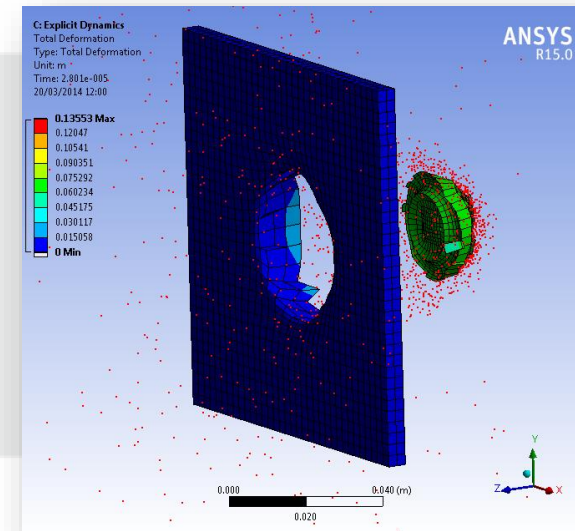

**CREDITS: 10**

**TOPICS:**

- Introduction to Dynamic Analysis
- Modal Analysis
- Response to Harmonic Loading
- Spectrum & PSD Analysis
- Response to General Dynamic Loading
  - Implicit Methods
  - Explicit Methods





## MODULE OBJECTIVE

This module will provide the adequate theoretical and practical background to analyze thermal problems through numerical simulations based on the finite element method (FEM) with Ansys Mechanical.

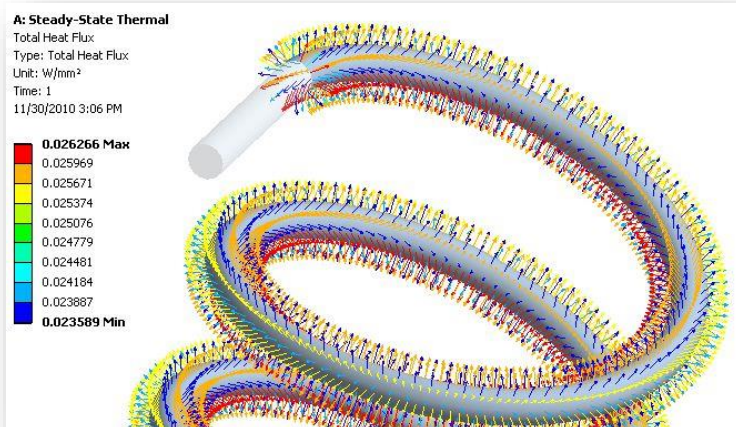
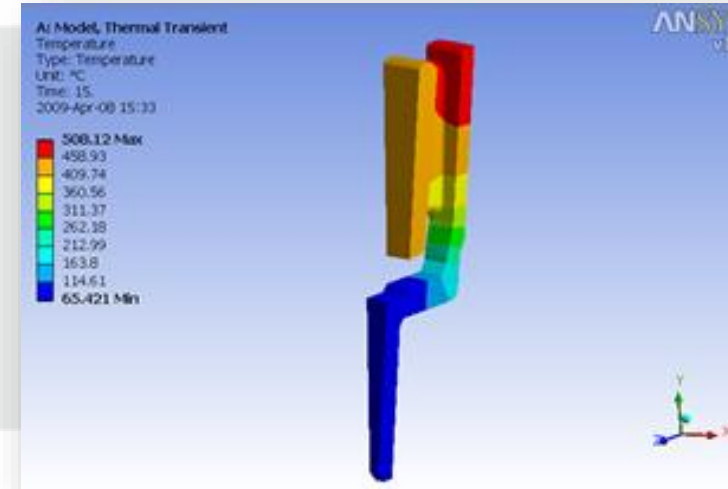

**CREDITS: 10**

**TOPICS:**

- Basic Concepts of Heat Transfer:
  - Conduction, Convection & Radiation
  - Steady-State and Transient Thermal Analysis
  - Phase Change
  - Thermo-Mechanical Analysis: Weak and Strong Coupling
  - Thermo-Electrical Analysis



## MODULE OBJECTIVE

This module will provide the adequate theoretical and practical background to analyze fracture and fatigue problems through numerical simulations based on the finite element method (FEM) with Ansys Mechanical and Ansys nCode.

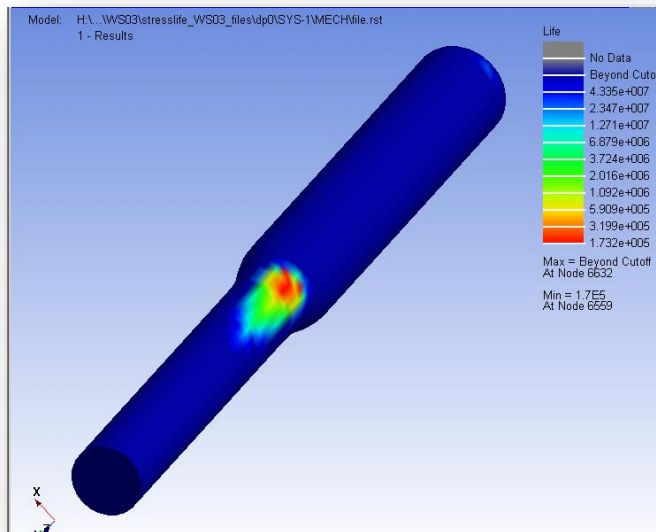
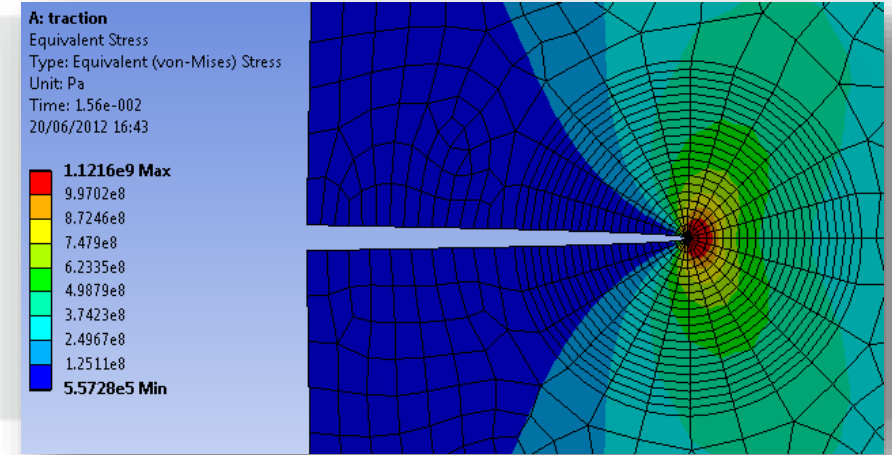

**CREDITS: 10**

**TOPICS:**

- Introduction to Fracture Analysis
  - Stress Intensity Factor (SIFs)
  - J-Integral
  - Energy Release Rate (G)
  - Definition of Fracture Analysis
    - Fracture Tool (Crack, Premeshed Crack, Postprocessing)
- Introduction to Fatigue Analysis
  - Definition of Fatigue Analysis
  - Stress Life Analysis
  - Strain Life Analysis



## MODULE OBJECTIVE

The objective of this module is to obtain both the theoretical and practical knowledge related to optimization in Solid Mechanics with Ansys.

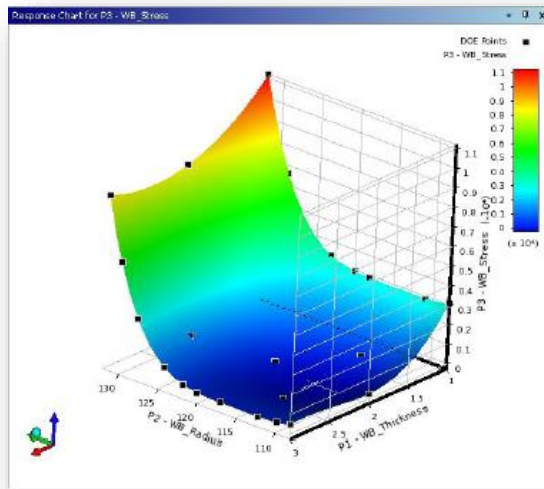
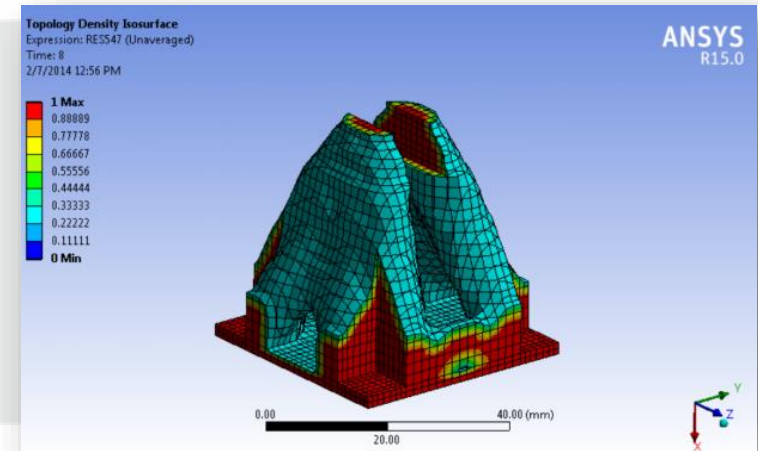

**CREDITS: 10**

**TOPICS:**

- Parametric Optimization with DesignXplorer
  - Parameters Correlation
  - Design of Experiments
  - Response Surface
  - Goal Driven Optimization
  - Robust Design and Six Sigma Analysis
- Solids Topological Optimization
  - In GENESIS Topology for Ansys Mechanical



## MODULE OBJECTIVE

The objective of this module is to be able to set up different simulation schemes between CFD and FEM codes to study phenomena arising from fluid-structure interaction and provide coupled results for both fields.

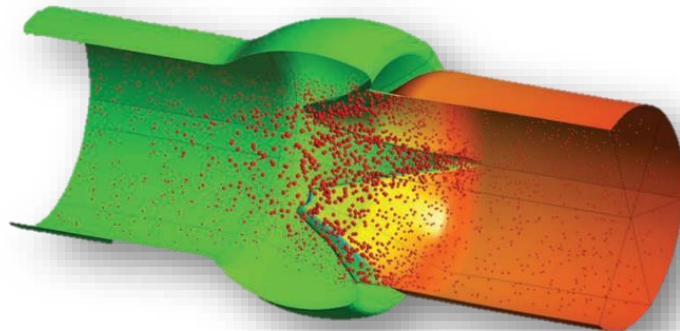
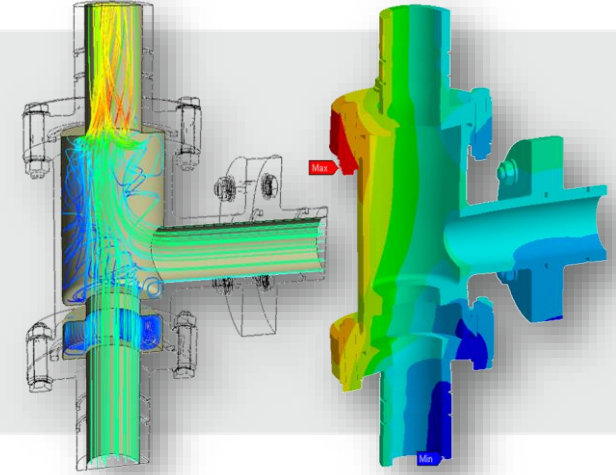

**CREDITS: 10**

**TOPICS:**

- 1-Way and 2-Way Fluid Structure Interaction
- Structural FSI
- Thermal FSI
- Thermo-Structural FSI
  - Moving and Deforming Meshes
- 6 DOF



The objective is to provide the adequate theoretical and practical background to analyze electromagnetic problems through numerical simulations.

## Basic Module

- Introduction to Electromagnetics: Theory and Simulation



## MODULE OBJECTIVE

The objective is to provide theoretical and practical background to analyze electromagnetic problems through numerical simulations

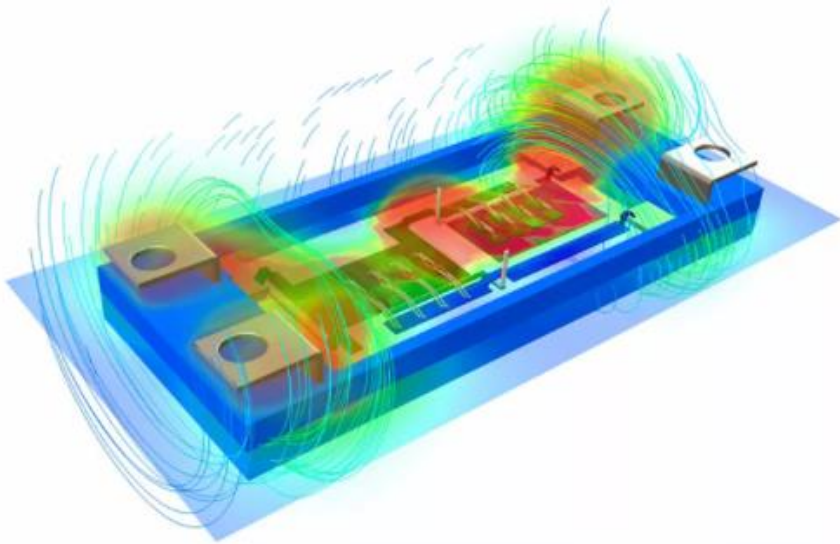
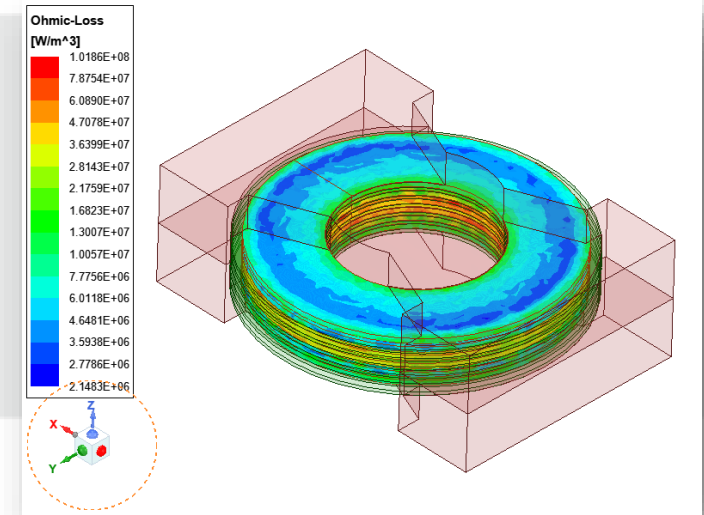

**CREDITS: 20**

**TOPICS:**

- Fundamentals: Introduction and Background
- Time-invariant Electric Field
- Time-invariant Magnetic Field
- Slowly Time-varying Electromagnetic Fields
- Maxwell's Equations in Advanced Applications
- Numerical Methods

# Learning Method

Numerical Simulation in Engineering

**Ansys**



The master's degree learning methodology is entirely online and includes documentation, exercises, tutorials, online evaluation, tutor sessions, forum and exams in **English**. The student has access to all learning materials through the virtual classroom.

## Additional Details:

- All instructional material has been created by the Technical University of Madrid and Ansys.
- For the software applications, students have access to Ansys software and licenses needed to perform exercises, tutorials, exams and the master's degree thesis.
- Contact with the professors is conducted through the virtual classroom, tutor sessions or forum. Communication between student and professor can be done in English or Spanish.
- Student evaluation is conducted via homework assignments and midterm tests for each module and an evaluation of the master's thesis.



# Using Ansys Software

- Installed on student's machine
- Connected to the University license server
- Teaching License to complete Modules
- Research License to complete Master's Thesis



# Degree Benefits

Numerical Simulation in Engineering

**Ansys**

# / Why Ansys and UPM?

**#1**

In engineering simulation



**#1**

In engineering education in Spain



# / Aligned with Industry Needs

Learn how to effectively apply Numerical Simulation in engineering.

Align **practical** and **theoretical** concepts in

- Fluid mechanics
- Solid mechanics
- Electronics

with **advanced calculations on industry-related use cases.**



# / Who Would Benefit from this Program?

**Students** – Gain skills for career



**Companies** – Employee skills development



**Engineers** – Career advancement

[Testimonial from Ryan Schultz](#)

# Resumes Stand Out with Ansys

Skills That Affect Mechanical Engineer Salaries	
<i>Different skills can affect your salary. Below are the most popular skills and their effect on salary.</i>	
Project Management	▲ 4%
Finite Element Analysis (FEA)	▲ 4%
Pro/Engineer	▲ 4%
ANSYS Simulation Software	▲ 3%
Engineering Design	▲ 1%
Microsoft Office	▼ 1%
Microsoft Word	▼ 1%
Microsoft Excel	▼ 2%
SolidWorks	▼ 3%
Autodesk AutoCAD	▼ 6%

\*Information pulled from [PayScale](#).

Everyone knows CAD and Microsoft – **Ansys and simulation trained students command a premium.**

# Alumni Network on LinkedIn



**Public Alumni Group on LinkedIn: Online Master's Degree in Numerical Simulation in Engineering with Ansys**

1500+ Members

Networking

Job Postings

# Teaching Staff

Numerical Simulation in Engineering

**Ansys**





## Ricardo Perera

Director of the Master's Degree Program

**Education:** PhD Mining Engineering

**Research Interests:** Material modelling, computational mechanics, strengthening of concrete structures with FRP composites, structural health monitoring in mechanical and civil engineering and soft computing.

**Experience & Accomplishments:** Authored more than 85 journal papers, has an h-index of 26, participated in more than 150 conferences and seminars, member of the editorial board of four international journals.



## Félix Arévalo

Associate Professor

**Education:** PhD Aeroelasticity, Polytechnic University of Madrid

**Experience & Accomplishments:**

Before 1999: 2Y experience in aerodynamic design of turbine Blades of turbofan-type engines (ITP and Honeywell Aerospace – USA).

1999-now: 22Y experience in Loads, Structural Dynamics and Aeroelasticity (SD&A) within AIRBUS Defense & Space, working in different projects as C-295, AIRBUS-Derivatives (Refueling tankers as A310-Demo or A330-MRTT and Boom System), A400M, Eurofighter (EF-2000), Falcon FX, and Eurodrone.



## Gustavo Guinea

Professor & Director of the Center for Biomedical Engineering

**Education:** PhD Engineering, Polytechnic University of Madrid

**Research Interests:** Research focused in the development of new bioinspired fibers for scaffolding and tissue regeneration and on the characterization and modeling of mechanical properties and microstructure of biological fibers and soft biological tissues.

**Experience & Accomplishments:** Awarded the RILEM's Robert L'Hermite Medal in 1993, appointed to National Correspondent Member of the Royal Spanish Academy of Sciences in 2006, served as President of the Spanish Structural Integrity Society in the period 2001-2009, authored more than a hundred indexed scientific papers, has an H-Index of 39.

# UPM - Electromagnetic Discipline Coordinator



## Miroslav Vasić

Associate Professor

**Education:** PhD Industrial Electronics

**Research Interests:** Power electronics applications (in the field of telecom, automotive and renewable energy applications), power converter modeling, optimizations and research of new semiconductor wide bandgap devices based on GaN and SiC.

**Experience & Accomplishments:** Advised 20+ Master Thesis and 2 Doctoral dissertations, published 20+ journal papers and 50+ technical papers, holds 5 patents, and awarded a Medal for his Research Trajectory by the Royal Academy of Engineers, Spain and the Best Young Researcher Award by UPM.

[Learn more about Miroslav here.](#)

# UPM - Electromagnetic Discipline Coordinator



**Alberto Delgado**

Teaching Assistant

**Education:** BSc Electrical Engineering, MSc Industrial Electronics

**Research Interests:** Power electronics applications in the field of modeling of dc-dc converters for inductive power transfer system, magnetic components for different applications, such as RFID communications and wireless charging, and magnetic nano-materials and micro-materials.

**Experience & Accomplishments:** Advised 20+ Degree and Master Thesis, published several journal and technical papers.

[Learn more about Alberto here.](#)

# Calendar & Fees

Numerical Simulation in Engineering

**Ansys**

# / Calendar

## First Semester

Enrollment period: June 1st 2021 - October 10th 2021

Registration period: July 16th 2021 - October 15th 2021

Teaching period: October 4th 2021 - January 30th 2022

## Second Semester

Enrollment period: November 15th 2021 - March 6th 2022

Registration period: December 15th 2021 - March 15th 2022

Teaching period: February 28th 2022 - June 26th 2022

# / Fees

The student has complete flexibility to choose the module(s) to follow each semester and

- The total cost of the Degree is paid progressively before the starting of each semester.
- The student will only pay for the credits he will take during that period.
- If the student decides to leave the Master temporarily, he/she may reincorporate again keeping his/her prior condition.

The Master's Degree fee is 80€ per ECTS-credit. For each module:

Module	Fee (€)
<b>Fundamentals and Application of Finite Element Method in Mechanical Analysis</b>	1600
<b>Fundamentals and Application of Computational Fluid Dynamics</b>	1600
<b>Introduction to Electromagnetics: Theory and Simulation</b>	1600
<b>Dynamic Analysis</b>	1600
<b>Thermal Analysis</b>	800
<b>Contact Non-linearities</b>	800
<b>Advanced Non-linearities</b>	800
<b>Fracture and Fatigue</b>	800
<b>Solids Optimization</b>	800
<b>Turbulence</b>	800
<b>Multiphase</b>	1600
<b>Heat Transfer</b>	800
<b>Combustion and Reactions</b>	800
<b>Turbomachinery</b>	800
<b>Fluids Optimization</b>	800
<b>Fluid-Structure Interaction</b>	800
<b>Master's Thesis</b>	1600



# Important Links and Contact Information

- [Master's Degree Website](#)
- [Pre-Enrollment](#)
- [Technical University of Madrid \(UPM\)](#)
- [Linkedin](#)
- [E-mail](#)
- [Ansys Academic Program](#)

The Ansys logo is positioned on the left side of the slide. It features a yellow slanted bar to the left of the word "Ansys" in a bold, black, sans-serif font.

**Ansys**

